

pottery barn kids

OLIVIA PLAY TABLE

PRE-ASSEMBLY:

- Please read all instruction before beginning assembly. The illustrations provided allow for easier assembly when used in conjunction with the assembly instructions.
- Remove all parts and hardware from box and lay out on a carpeted or scratch-free work surface, as this will avoid damaging any parts during assembly. The shipping box provides an ideal work surface. Do not dispose of any contents until assembly is completed to avoid accidentally discarding small parts or hardware.
- For your safety and ease, adult assembly by two people is recommended.
- Save all packing materials until assembly is complete to avoid accidentally discarding smaller parts or hardware.
- Use the parts and hardware lists to identify and separate each of the pieces included prior to starting assembly.
- Note: Do not fully tighten all bolts until all parts are in place. Failure to follow these instructions may cause the bolts to misalign during assembly.
- If using power tools to aid in assembly please use caution. Power tools can damage hardware or split wood.

PARTS INCLUDED:

- (A) Table top - 1pc
- (B) Leg - 4pcs

HARDWARE ENCLOSED:

- (C) Nut – 8pcs



- (D) Washer – 8pcs



- (E) Spring washer – 8pcs



- (F) Wrench – 1pc

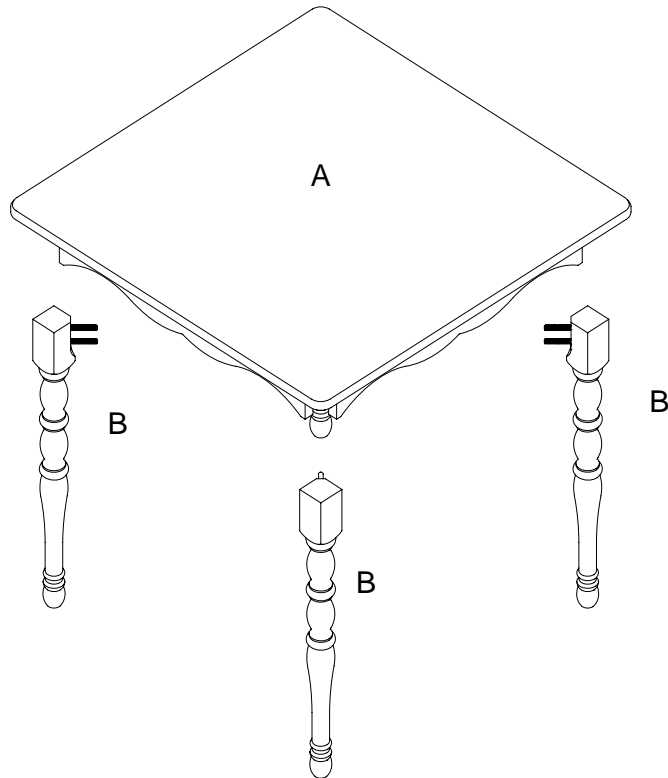
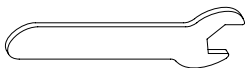

ASSEMBLY INSTRUCTIONS:

1. Lay Table Top (A) upside down on a soft surface such as a carpet. Insert the two leg bolts on the leg (B) into the pre-drilled holes on the corner block of the table top. Fasten each bolt with Washer (D), Spring Washer (E), and Nut (C), using the Wrench (F) as shown in Figure 1. Repeat the same process for remaining legs. Turn the Table upright.

(Fig 1.)

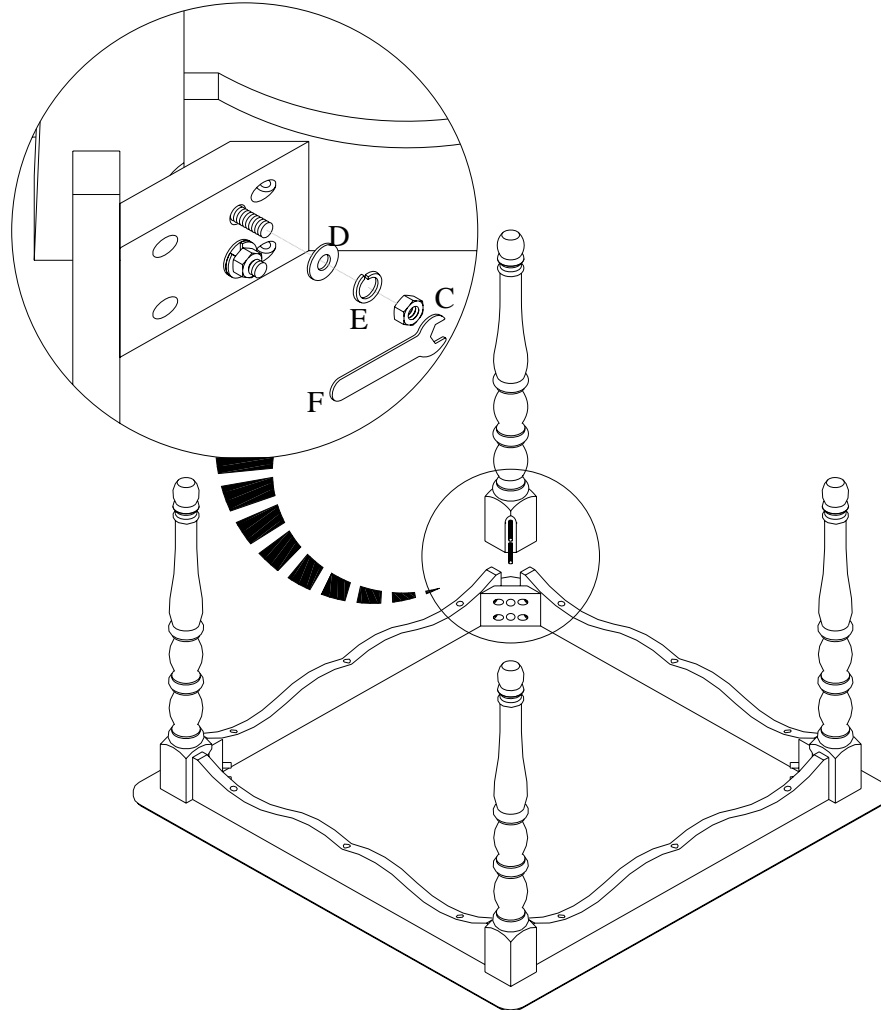

CARE INSTRUCTIONS:

- Dust often using a clean, soft, dry lint-free cloth.
- Blot spills immediately, and wipe with a clean, damp, cloth.
- We do not recommend the use of chemical cleansers, abrasives, or furniture polish on our lacquered finish.

Thank you for your purchase
stores | catalog | www.potterybarnkids.com
USA 1.800.290.8181