

# pottery barn kids







## CHESAPEAKE STORAGE TOWER

**CAUTION** : Adult assembly required. This item contains small parts that have sharp points and edges in the unassembled state. Adults should take care when unpacking and assembling this item.

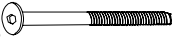
### PARTS INCLUDED

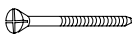
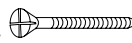
A. Right panel	1 Pc
B. Left panel	1 Pc
C. Back panel	1 Pc
D. Door	1 Pc
E. Horizontal bar	1 Pc
F. Top panel	1 Pc
G. Bottom panel	1 Pc
H. Bottom tray	1 Pc
I. Middle trays	2 Pcs
J. Handle	1 Pc

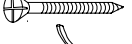
### HARDWARE ENCLOSED

K. 60 mm Bolts		= 8 Pcs
L. Metal Pins		= 8 Pcs
M. 6 x 1 1/2" Screw		= 4 Pcs
N. 8 x 1 1/2" Screw		= 2 Pcs
O. 6 x 1" Screw		= 15 Pcs
P. 6 x 3/4" Screw		= 6 Pcs
Q. 8 x 1 1/4" Screw		= 1Pc
R. Metal hook		= 1Pc
S. 6 x 1/2" Screw		= 2 Pcs

### TOOLS REQUIRED

Bolt Key		(included) = 1
Phillips Screwdriver		(not included) = 1

#### PRE-ASSEMBLY:

- Carefully lay pieces on a carpeted or scratch- free surface (the shipping box provides an ideal work surface).
- Please do not tighten the hardware fully until the piece is completely assembled. Once the bin is assembled, tighten all hardware completely making sure all pieces are in alignment.

#### ASSEMBLY INSTRUCTIONS:

1. Assemble the Handle (J) to Door panel (D) as shown with the 8 x 1 1/4" Screw (Q) (Fig. 1). The handle must be screwed from inside of the door. Take notice of the magnets on the upper left and bottom left inside the door.

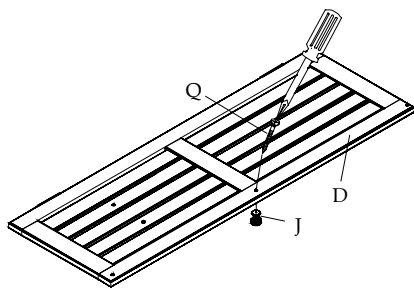

(Fig. 1)

- Place the Back Panel (C), Right Panel (A), Left Panel (B), and Horizontal Bar (E) as shown, securing with the 60 mm Bolts (K). Take notice of the magnet on the right upper corner of horizontal bar. This magnet should be facing out. (Fig. 2)

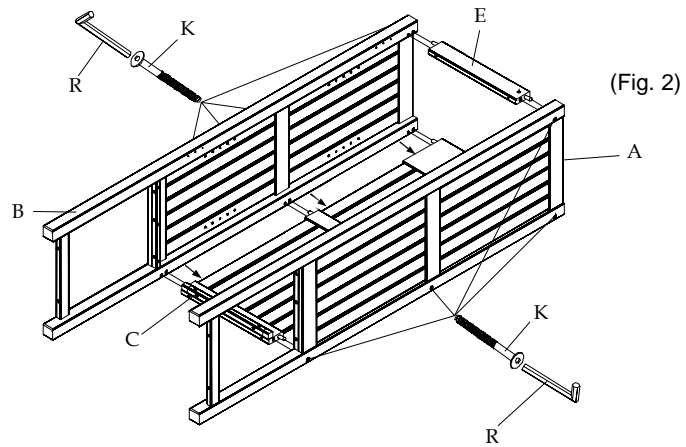

- Place the Top Panel (F), Bottom Panel (G), and Bottom Tray (H) as shown, securing them with 2, 8 x 1 1/2" Screws (N), Screwing them from the Horizontal Bar (E) to the Top Panel (F). (Fig. 3)

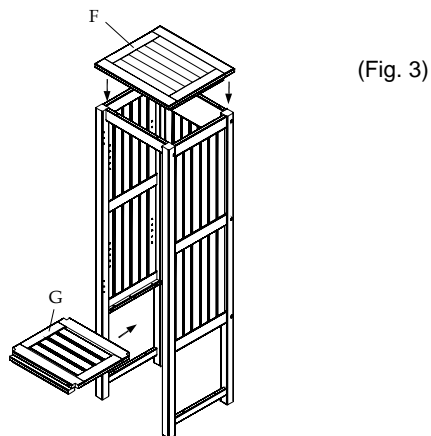

- Secure the remaining connections of Top Panel (F) to the Right/Left/Back Panels (A,B,C) with 6 of the 6 x 1" Screws (O). Repeat this step with the Bottom Panel (G) with 9 of the 6 x 1" Screws (O), and with the Bottom Tray (H) with 4 of the 6 x 1 1/2" Screws (M). Ensure that the magnet on the Bottom Panel (G) is facing out. Do not fully tighten the screws yet. (Fig. 4)

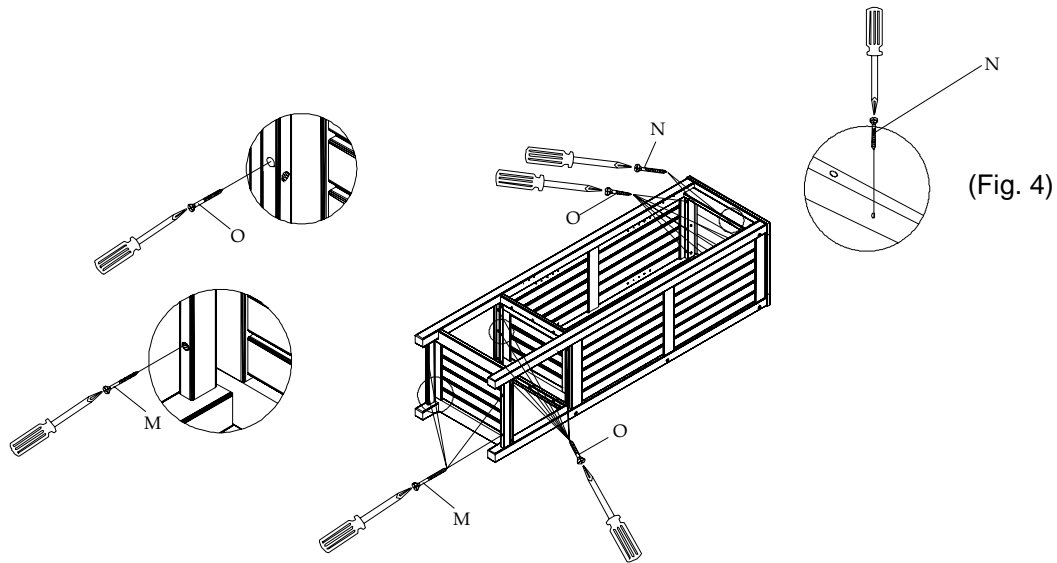

- Carefully stand the assembled Tower upright and secure the hinges to the frame with 6 of the 6 x 3/4" Screws (P). Ensure the door is properly aligned before you tighten the screws. (Fig. 5)

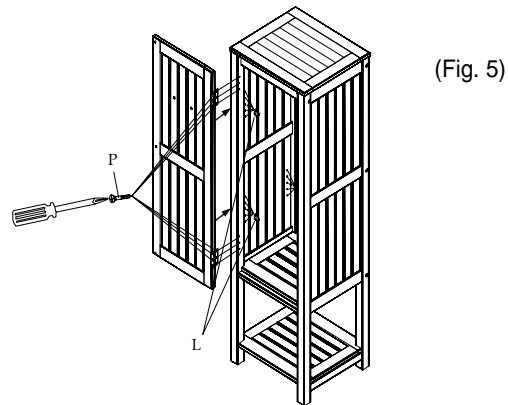

- Insert the Metal Pins (L) in the desired holes of the interior walls of the assembled tower, and carefully place the Middle trays (I). (Fig. 6)

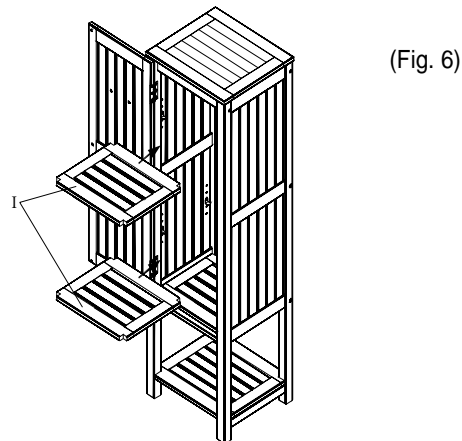

7. Remove the middle shelf and place the Metal Hook (R) at the Back Panel (C), securing with 2 of the 6 x 1/2" Screws (P). (Fig. 7)

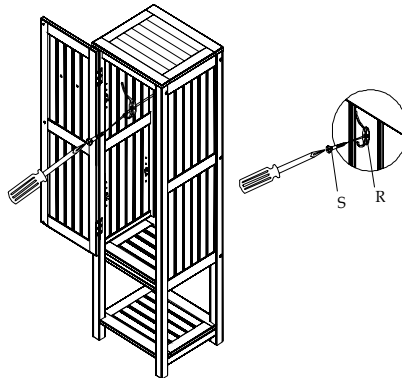

(Fig. 7)

8. Ensure all bolt and screws are aligned properly, and then tighten to secure all the connections.

#### CARE INSTRUCTIONS:

- For daily care wipe with a soft dry cloth. Wipe spills with clean dry cloth. Avoid the use of harsh cleaners and abrasive.
- Do not use oil. For maintaining the finish, wash using a mild soap and cleanser to remove accumulated dirt. Cover during storage or when not in use using a proper outdoor cover allowing adequate ventilation without trapping moisture. Do not cover with plastic or similar materials that will trap moisture.
- Store in a dry, covered area when not in use.

Thank you for your purchase  
stores | catalog | [www.potterybarnkids.com](http://www.potterybarnkids.com)  
USA 1.800.290.8181