

pottery barn kids

EMERY DESK

PRE-ASSEMBLY:

- Please read all instruction before beginning assembly. The illustrations provided allow for easier assembly when used in conjunction with the assembly instructions.
- Remove all parts and hardware from box and lay out on a carpeted or scratch-free work surface, as this will avoid damaging any parts during assembly. The shipping box provides an ideal work surface. Do not dispose of any contents until assembly is completed to avoid accidentally discarding small parts or hardware.
- For your safety and ease, adult assembly by two people is recommended.
- Save all packing materials until assembly is complete to avoid accidentally discarding smaller parts or hardware.
- Use the parts and hardware lists to identify and separate each of the pieces included prior to starting assembly.
- Note: DO not fully tighten all bolts until all parts are in place. Failure to follow these instructions may cause the bolts to misalign during assembly.
- If using power tools to aid in assembly please use caution. Power tools can damage hardware or split wood.

PARTS INCLUDED:

(A) Top panel – 1pc

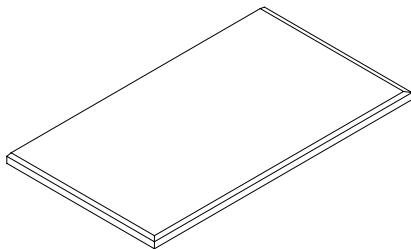

(B) Cabinet with drawer – 1pc

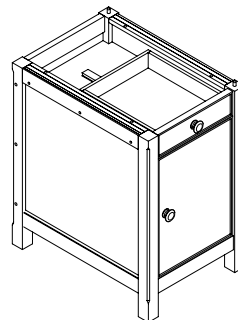

(C) Left side panel – 1pc

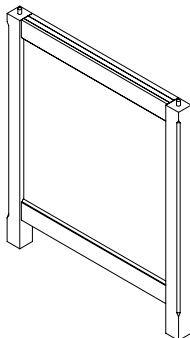

(D) Keyboard tray with frame – 1pc

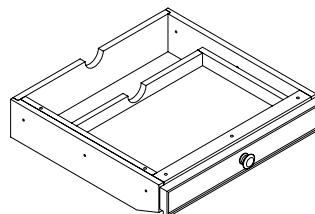

(E) Back panel – 1pc

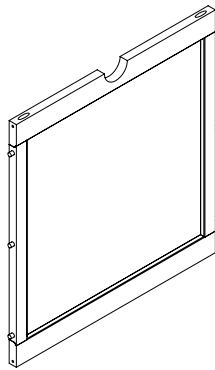

(F) Shelf – 1pc

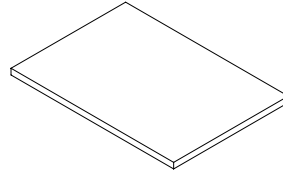

TOOLS REQUIRED:

Phillips head screwdriver (not included)

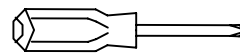

HARDWARE ENCLOSED:

(G) Allen Bolts 1/4"x32mm – 15pcs

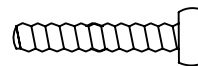

(H) Allen Key 4x74x29mm – 1pc



(I) Small Phillips head screw 8x32mm – 4pcs



(J) Shelf support – 4pcs



(K) Wooden dowel 10x40mm – 2pcs



ASSEMBLY INSTRUCTIONS:

1. Remove the Keyboard tray (D) from the frame and the drawer from the drawer compartment on the Cabinet (B) as shown.
2. Attach the Keyboard tray frame (D) to the Cabinet (B) using Allen bolts (G) and Allen key (H). See illustration below. Insert the wooden dowels (K) to the Cabinet (B).

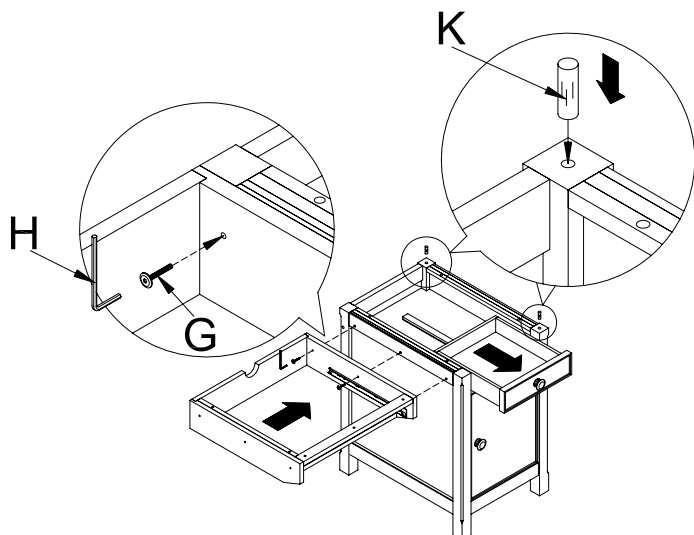
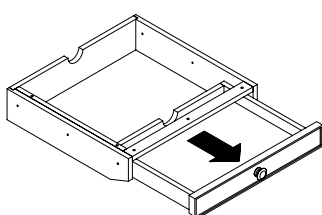

3. Attached the Back panel (E) to the Cabinet (B) and Left side panel (C) using the Small Philips screws (I) as shown. Assemble the Keyboard tray frame (D) to the Left side panel (C) using the Allen bolts (G) and fastening with the Allen key (H).

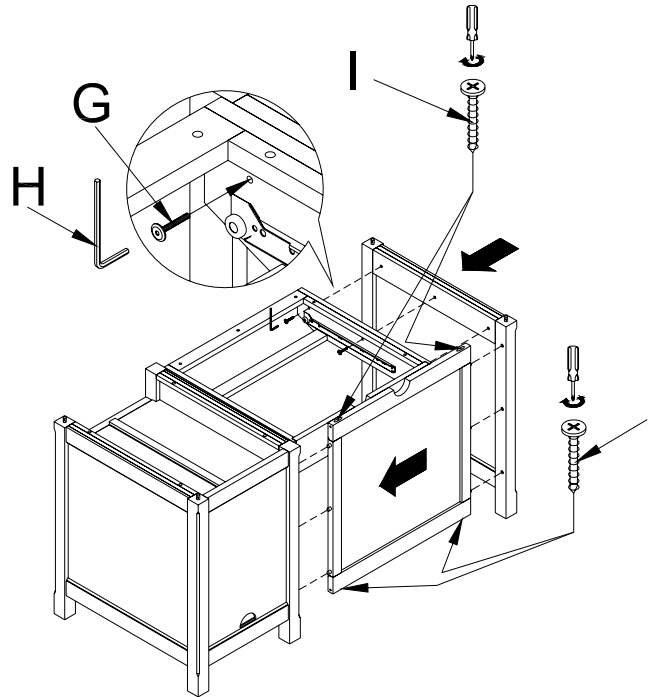

4. Attach the Top panel (A) to the desk using the Allen bolts (G) and fastening with the Allen key (H) as shown.

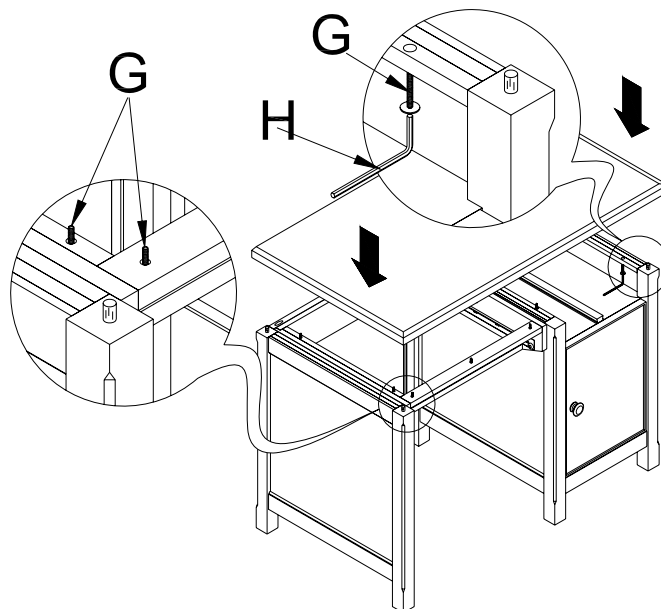

5. Determine the desired height for shelf using the Shelf support (J) to place the Shelf (F) in the desk interior.

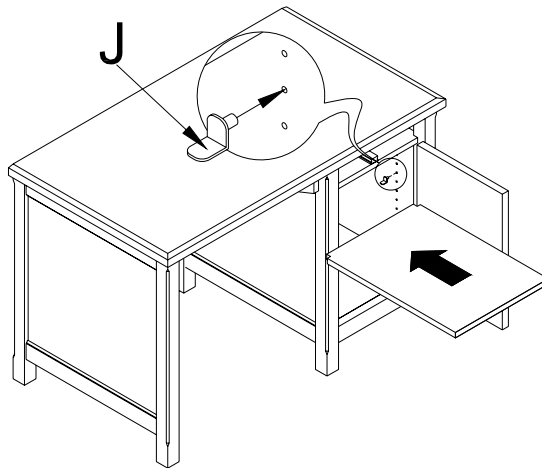

6. Insert the side drawer and keyboard tray (D) as shown.

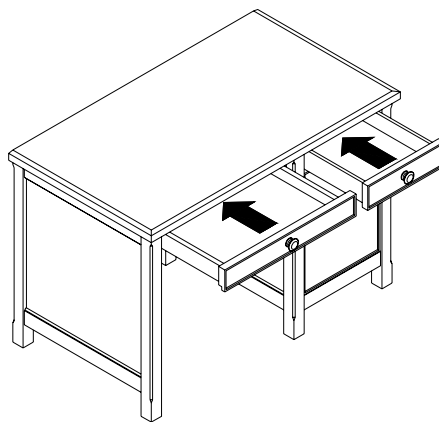

CARE INSTRUCTIONS:

- Dust often using a clean, soft, dry lint-free cloth.
- Blot spills immediately, and wipe with a clean, damp, cloth.
- We do not recommend the use of chemical cleansers, abrasives, or furniture polish on our lacquered finish.

Thank you for your purchase.

stores | catalog | www.potterybarnkids.com

USA 1.800.290.8181