

pottery barn kids

CAMERON SMALL DESK

IMPORTANT SAFETY INSTRUCTIONS:

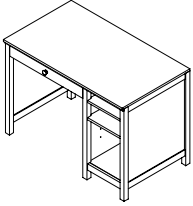



Please read all instructions carefully before assembling.
For your safety, assembly by two people is recommended.



PART LIST

- (A) Desk Top – 1pc
- (B) Keyboard Tray – 1pc
- (C) Leg Panel – 1pc
- (D) Desk Open Base – 1pc
- (E) Thin Shelf – 1pc
- (F) Thick Shelf – 1pc

HARDWARE LIST

- (G) Allen Key  - 1pc
- (H) Bolt 1/4" x 25mm  - 8pcs
- (I) Spring Washer 1/4"  - 8pcs
- (J) Flat Washer 1/4"  - 8pcs
- (K) Shelf Support  - 8pcs

PRE-ASSEMBLY:

- Remove all parts and hardware from the box and lay out on a clean, carpeted, or scratch-free work surface, as this will avoid damaging any parts during assembly. The shipping box provides an ideal work surface. Do not dispose of any contents until assembly is completed to avoid accidentally discarding small parts or hardware.
- Use the parts and hardware lists above to identify and separate each of the pieces included.
- The illustrations provided allow for easier assembly when used in conjunction with the assembly instructions.
- Note: Do not fully tighten all bolts until all parts are in place. Failure to follow these instructions may cause the bolts to misalign during assembly.
- If using power tools to aid in assembly please use caution. Power tools can damage hardware or split wood.

ASSEMBLY INSTRUCTIONS:

1. Carefully place the Table Top (A) face-down on your work surface. Place the Open Base (D) upside down on the Table Top. Align and connect (4) Bolt (H), Spring Washer (I) and Flat Washer (J) from interior of the Open Base to the pre-drilled holes on desk top piece. Align and secure the pre-drilled holes on the Leg Panel (C) to the pre-drilled holes on the other side of the Desk Top piece using the remaining (4) Bolt (H), Spring Washer (I) and Flat Washer (J). Do not fully tighten.

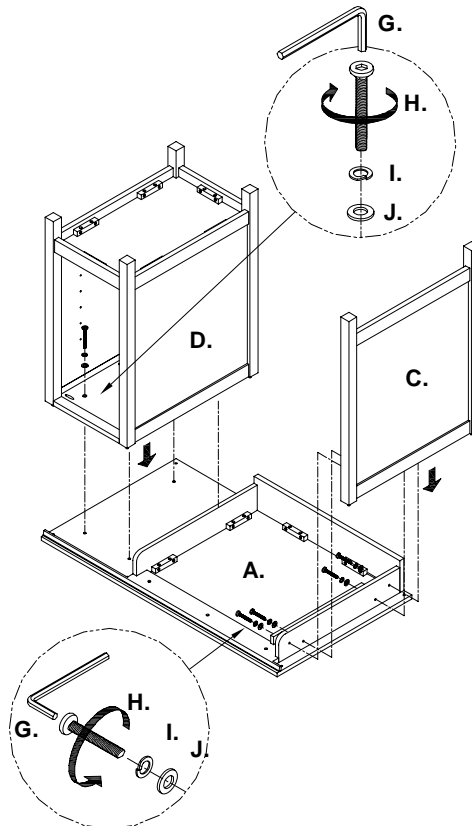

2. Turn the assembled piece in upright position. Check the alignment and tighten all bolts.
3. Attach the Keyboard Tray (B) to the pre-mounted metal glides under the desk top.

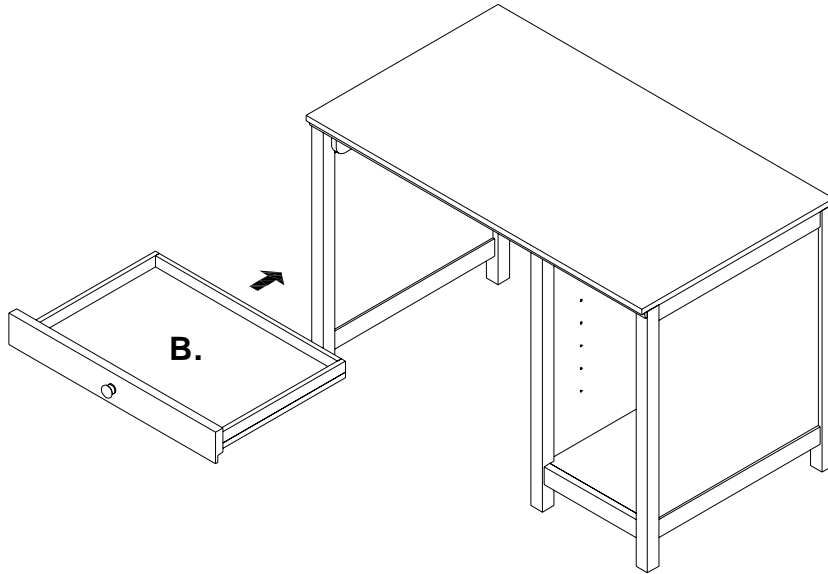

4. Insert the Shelf Support (K) to matching positions inside the Open Base. Place the (2) Shelf (E&F) on the Shelf Supports.

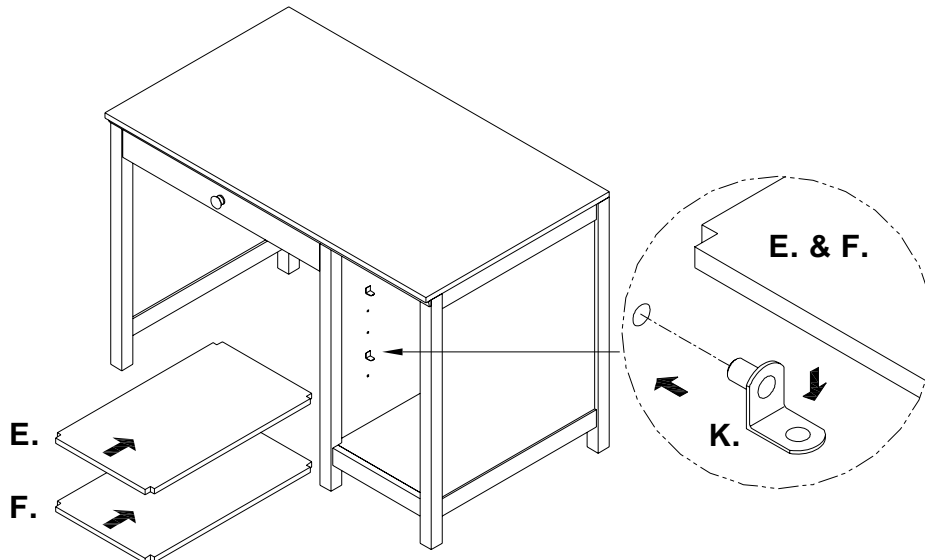

CARE INSTRUCTIONS:

- Dust with a clean, soft cloth.
- Bolt spills immediately, and wipe with a clean, damp, cloth.
- We do not recommend the use of chemical cleansers, abrasives, or furniture polish on our lacquered finish.

Thank you for your purchase
stores | catalog | www.potterybarnkids.com
USA 1.800.290.8181