

pottery barn kids

thomas corner hutch

PRE-ASSEMBLY:

- Remove all parts and hardware from the box and lay out on a clean, carpeted, or scratch-free work surface, as this will avoid damaging any parts during assembly. The shipping box provides an ideal work surface. Do not dispose of any contents until assembly is completed to avoid accidentally discarding small parts or hardware.
- Use the parts and hardware lists above to identify and separate each of the pieces included.
- The illustrations provided allow for easier assembly when used in conjunction with the assembly instructions.
- Note: Do not fully tighten all bolts until all parts are in place. Failure to follow these instructions may cause the bolts to misalign during assembly.
- If using power tools to aid in assembly please use caution. Power tools can damage hardware or split wood.

PARTS INCLUDED:

- (A) Top Cover – 1 pc
- (B) Top Panel – 1pc
- (C) Shelf – 1pc
- (D) Back Side Panel Left & Right – 2pcs
- (E) Front Side Panel Left & Right – 2pcs
- (F) Back Panel– 1pc

HARDWARE ENCLOSED:

- (G) JCBCW M7x95mm – 6pcs
- (H) CBS M3.5x16mm – 18pcs
- (I) PH rattan screw M5x45mm – 31pcs

TOOL REQUIRED:

- (J) Phillips head screwdriver (not included)
- (K) Allen key – 1pc (included)

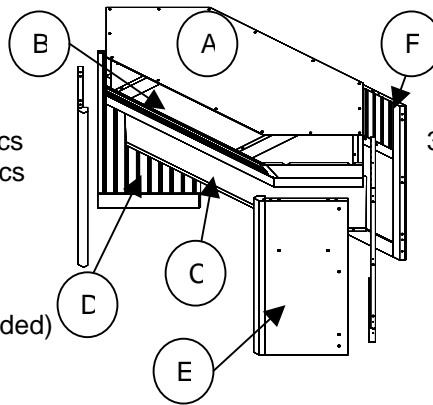

ASSEMBLY INSTRUCTIONS:

1. Align the pre-drilled holes of the Front Side Panel Right (E) & Back Side Panel Right (D). Fasten PH rattan screws (I) using Philips Head Screwdriver (J) to the Front Side Panel Right (E) (Fig.1). Repeat the same step for Front Side Panel Left (E) & Back Side Panel Left (D). (Fig. 2)

(Fig. 1)

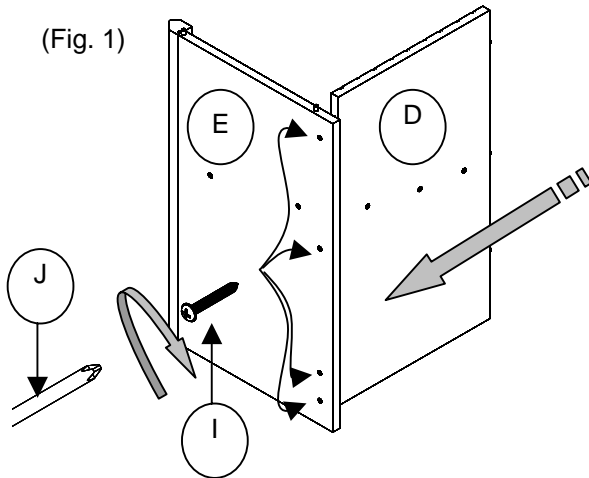

(Fig. 2)

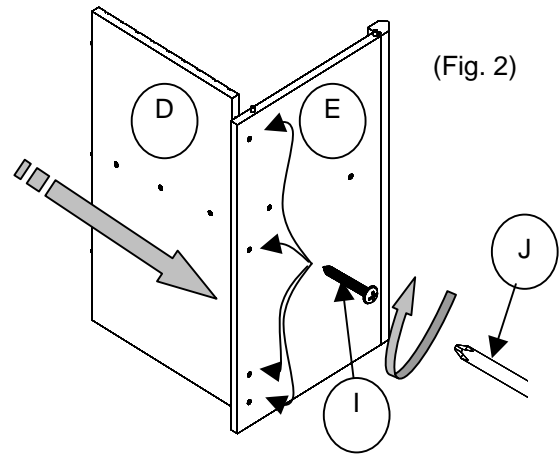

2. Carefully align the pre-drilled holes of the shelf (C) with those to the Back Panel (F). Fasten PH rattan screws (I) using Philips Head Screwdriver (J) to the Back Panel (F). (Fig. 3)

(Fig. 3)

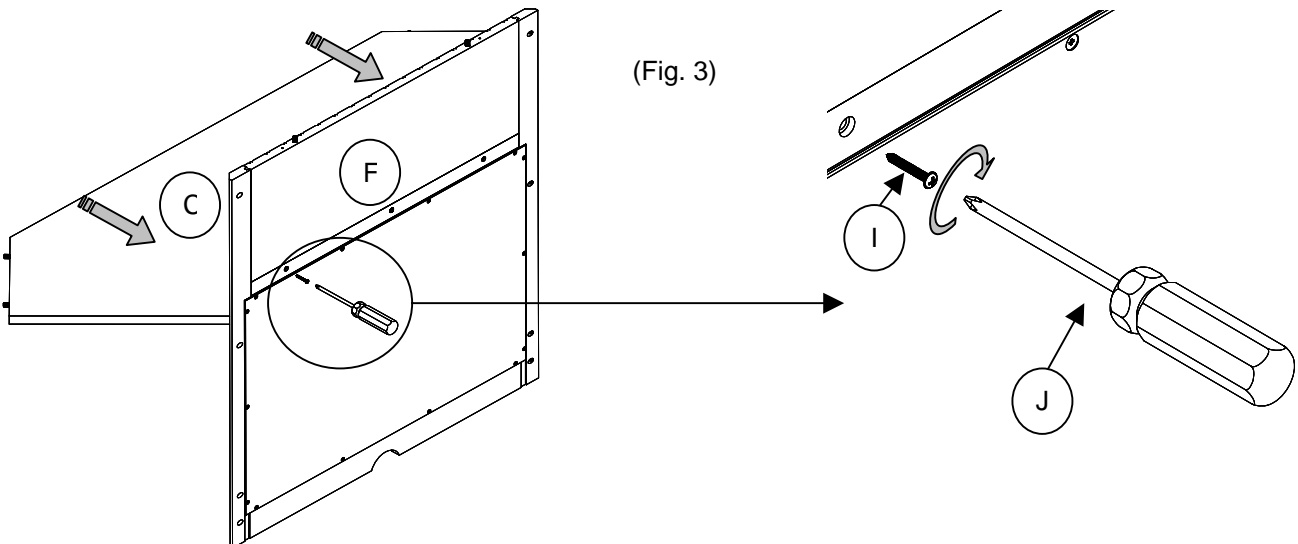

- Align the pre-drilled holes of the Front Side Panel Left & Right (E) & Back Side Panel Left & Right (D) with those to the Shelf (C) & Back Panel (F). Fasten PH rattan screws (I) using Philips Head Screwdriver (J) to the Front Side Panel Right (E) (Fig. 4) and Front Side Panel Left (E). (Fig. 5)

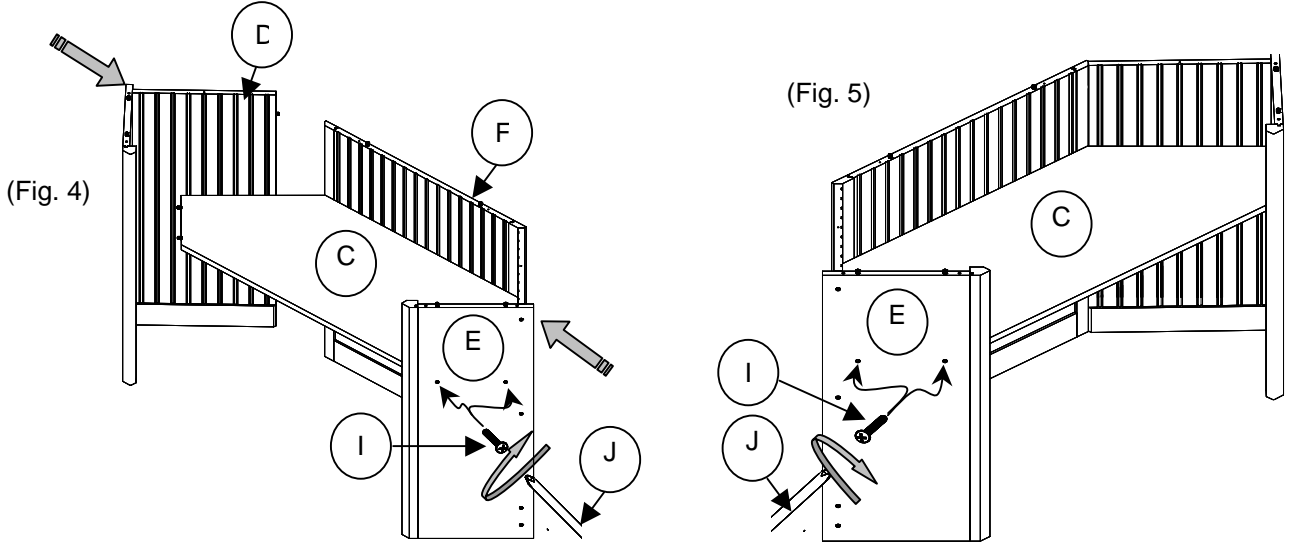

- Fasten PH rattan screws (I) using Philips Head Screwdriver (J) to the Back Panel (F) and Back Side Panel Left & Right (D). (Fig. 6)
- Align the pre-drilled holes of the Front Side Panel Left & Right (E) and Back Panel (F) with those on the Top Panel (B). Insert a JCBCW Screw (G) through the pre-drilled holes of the Top Panel (B) and into the pre-drilled holes of the Front Side Panel Left & Right (E) and Back Panel (F). Tighten using the Allen Key (K). (Fig. 7)

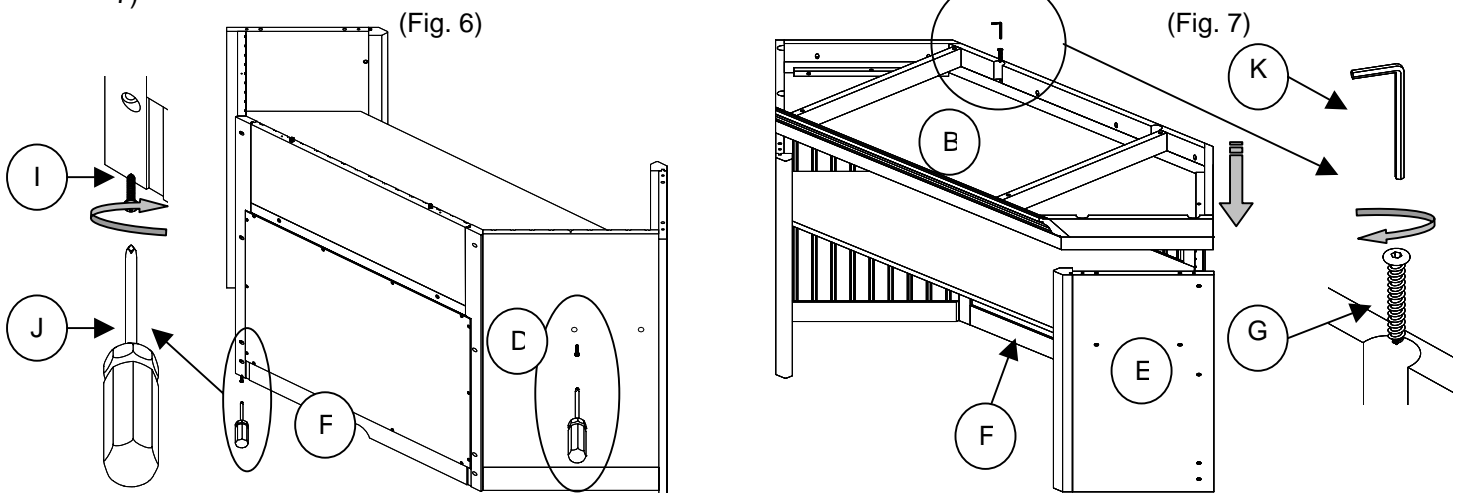

- Fasten CBS screws (H) using Philips Head Screwdriver (J) to the Top Cover (A). (Fig. 8)
- Assembly is complete. (Fig. 9)

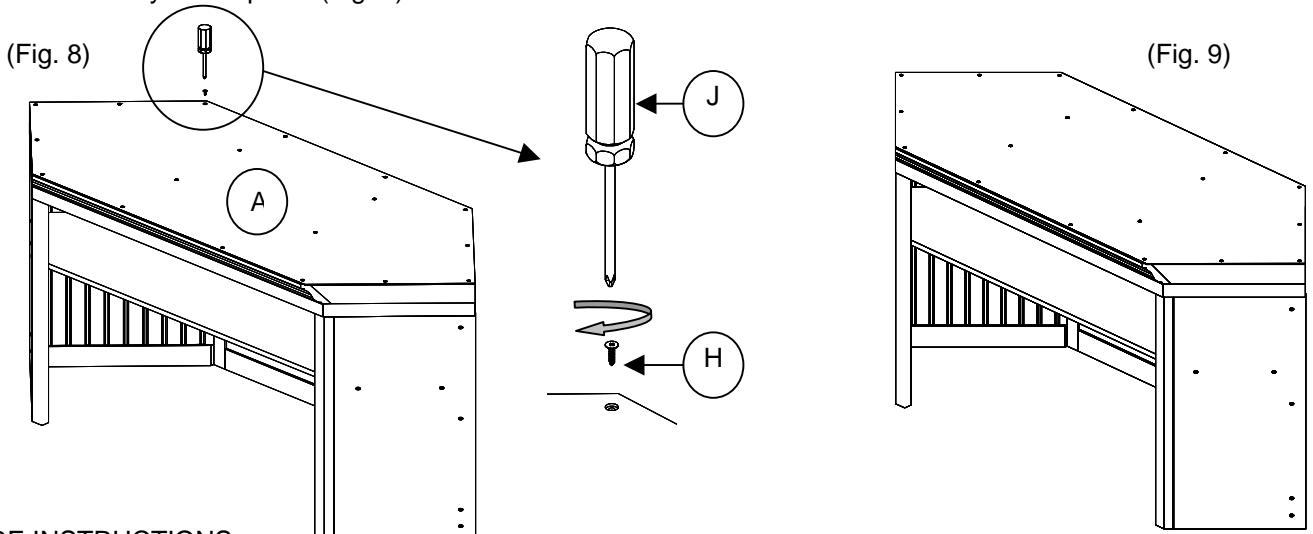

CARE INSTRUCTIONS:

- Use a soft dry or slightly damp cloth to clean periodically.
- To protect the finish always avoid the use of chemical and abrasive cleansers.