

# pottery barn kids

## THOMAS STORAGE DESK

### PRE-ASSEMBLY:

- Please read all instruction before beginning assembly. The illustrations provided allow for easier assembly when used in conjunction with the assembly instructions.
- Remove all parts and hardware from box and lay out on a carpeted or scratch-free work surface, as this will avoid damaging any parts during assembly. The shipping box provides an ideal work surface. Do not dispose of any contents until assembly is completed to avoid accidentally discarding small parts or hardware. **NOTE: knobs are placed inside the drawers for shipping.**
- For your safety and ease, adult assembly by two people is recommended.
- Save all packing materials until assembly is complete to avoid accidentally discarding smaller parts or hardware.
- Use the parts and hardware lists to identify and separate each of the pieces included prior to starting assembly.
- Note: DO not fully tighten all bolts until all parts are in place. Failure to follow these instructions may cause the bolts to misalign during assembly.
- If using power tools to aid in assembly please use caution. Power tools can damage hardware or split wood.

### PARTS INCLUDED:

(A) Top panel – 1pc

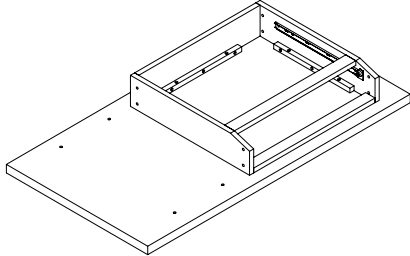

(B) Left side panel – 1pc

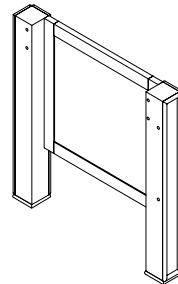

(C) Right side panel – 1pc

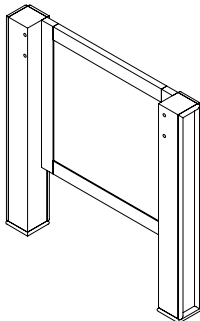

(D) Cabinet with drawer – 1pc

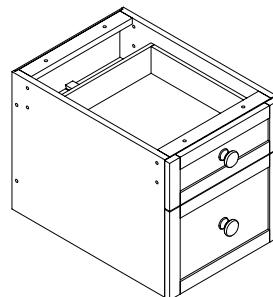

(E) Keyboard tray – 1pc

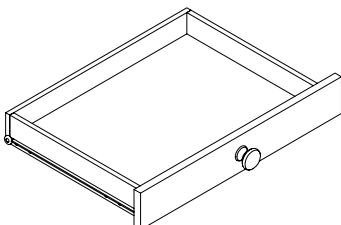

(F) Back panel – 1pc

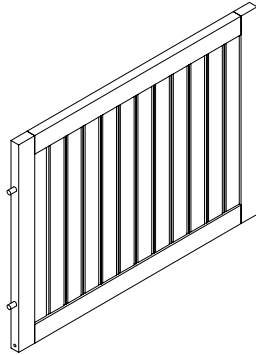

(G) Foot – 4pcs

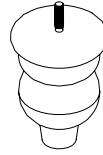

**TOOLS REQUIRED:**

Phillips head screwdriver (not included)

Allen Key (included)

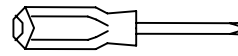

**HARDWARE ENCLOSED:**

(H) Allen Bolts 1/4"x32x15mm – 16pcs

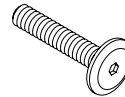

(I) Allen Key 4x74x29mm – 1pc



(J) Phillips head screw 8x38mm – 2pcs

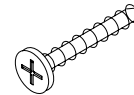

**ASSEMBLY INSTRUCTIONS:**

1. Attach the Feet (G) to the Side panel as shown. (Fig. 1)
2. Remove the drawers from the Cabinet (D) as shown. (Fig. 2)

(Fig. 1)

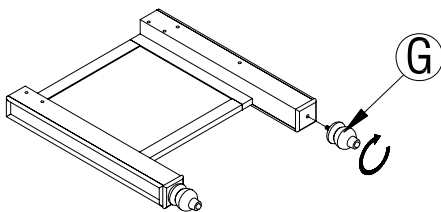

(Fig. 2)

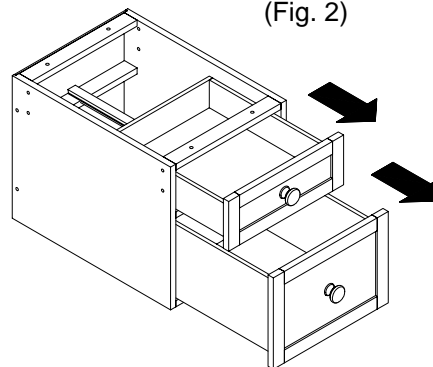

3. Attach the Cabinet (D) to the Top panel (A) using the Allen Bolts 1/4"x32x15mm (H) and Allen key (I). (Fig. 3)

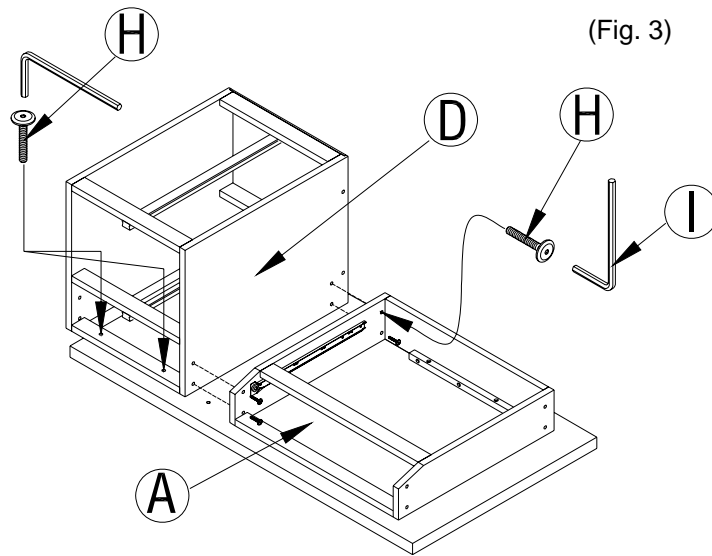

4. Attach the Right side panel (C) to the Cabinet (D) and Top panel (A) using the Allen Bolts 1/4"x32x15mm (H) and Allen key (I) as shown. (Fig. 4)

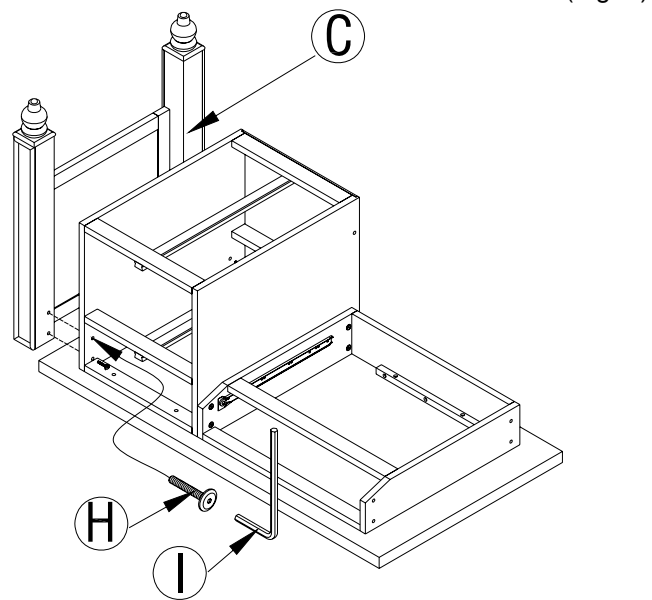

5. Attach the Left side panel (B) to the desk using Allen Bolts 1/4"x32x15mm (H) and Allen key (I) as shown.
6. Insert the Back panel (F) to Top panel (A) and Cabinet (D), and connect the assembly to the Left side panel (B) using Phillips head screw 8x38mm (J). (Fig. 5)

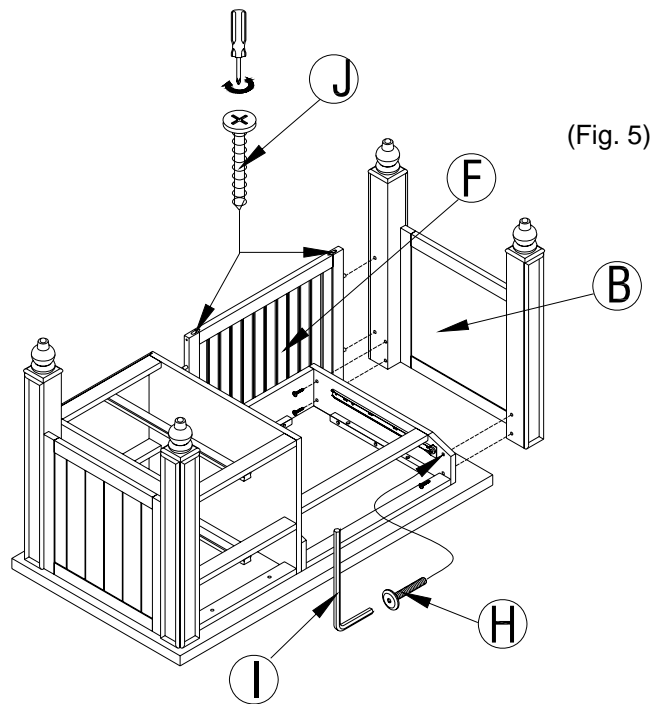

7. Insert the Keyboard tray (E) and drawers in the desk as shown. (Fig. 6)

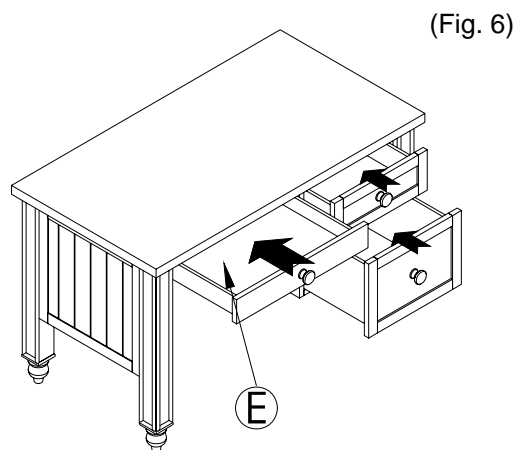

#### CARE INSTRUCTIONS:

- Dust often using a clean, soft, dry lint-free cloth.
- Blot spills immediately, and wipe with a clean, damp, cloth.
- We do not recommend the use of chemical cleansers, abrasives, or furniture polish on our lacquered finish.

Thank you for your purchase

stores | catalog | [www.potterybarnkids.com](http://www.potterybarnkids.com)

USA 1.800.290.8181